

TT Positioning Chart

OWNER NAME: _____

Full address: _____

Phone: _____

Email: _____

Bicycle serial number: _____

Manufacturer/Make: _____

Model: _____

Color(s): _____

A: Saddle Height: _____ **J:** Handlebar Angle: _____

B: Saddle Height Over Bars: _____ **K:** Extension Angle: _____

C: Saddle to Handlebar Reach: _____ **L:** Extension Width: _____

D: Saddle Angle: _____ **M:** Extension Width at End: _____

E: Saddle fore-aft: _____ **N:** Extension Length: _____

F: Saddle Brand and Model: _____ **O:** Elbow Rest Width: _____

G: Stem Length: _____ **P:** Elbow Rest Height: _____

H: Stem Angle: _____ **Q:** Handlebar Width: _____

I: Handlebar Brand and Model: _____ **R:** Crank Length: _____

Chainrings: _____

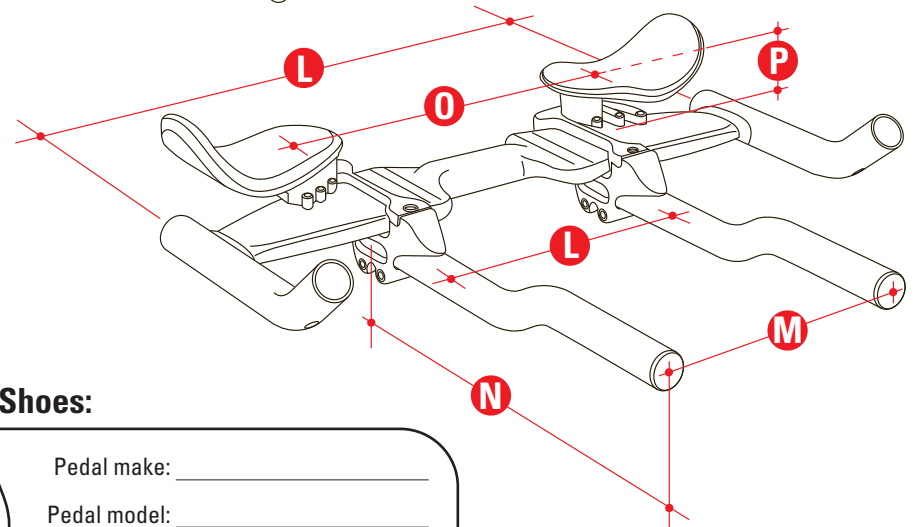
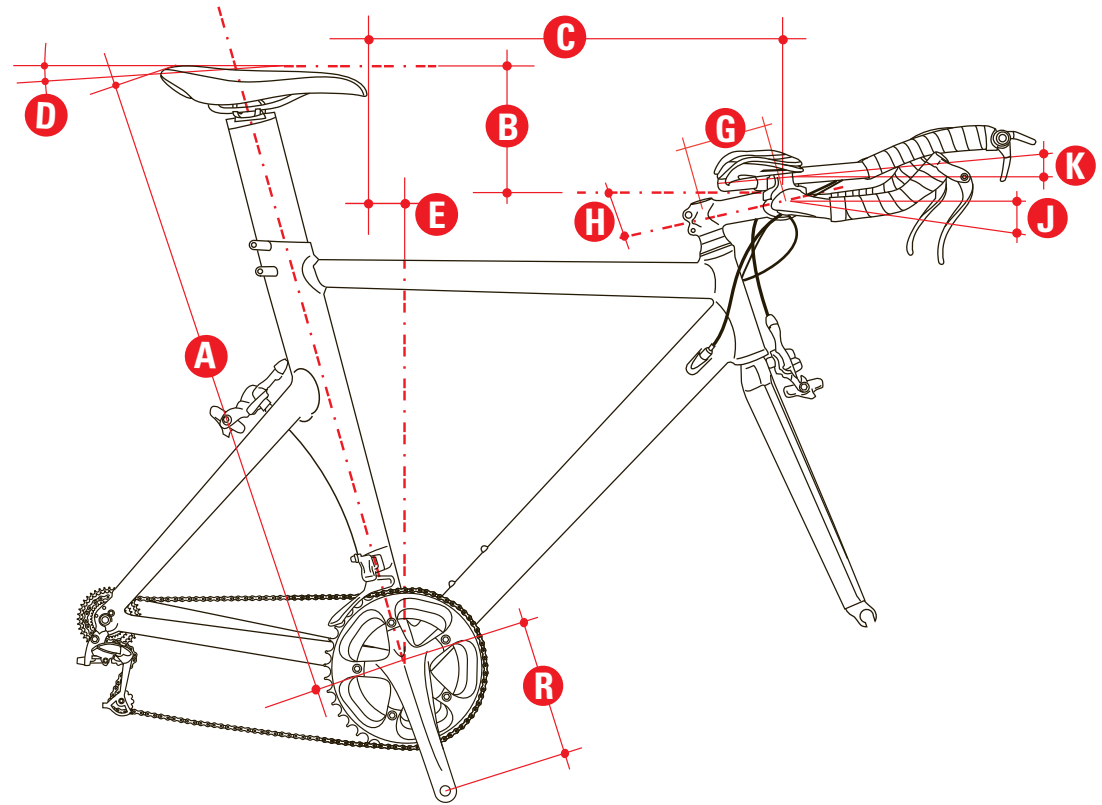

Pedal and Shoes:

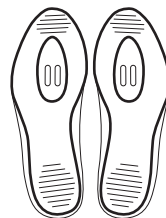

Pedal make: _____

Pedal model: _____

Shoe size: _____

Make/model: _____

Cleat position: _____